

# numatics®

## ADL Series

Drip Leg



[www.numatics.com](http://www.numatics.com)

**ADL Series**

The Numatics ADL Series Drip Leg in combination with coalescing filtration delivers an efficient and economical package for eliminating water and water aerosols from compressed air systems. Designed with an oversized expansion chamber, the ADL Series offers one of the best water removal efficiencies for drip legs on the market today. Standard features on the ADL Series include 1/4 turn ball valves on the inlet and drain ports which provide customers with a simple solution when system shutdowns are necessary on any "point of use" application. Inlet ball valve is a robust lockable-relieving construction (standard feature) that relieves downstream pressure when in the closed position.

**Features**

- Inlet Ball Valve Port Size: 1/4 to 2 NPTF
- Drain Ball Valve Port Size: 1/4 & 3/8 (NPTF & ISO228/1-G)
- Outlet Port Size: 1/4 to 2 (NPTF & ISO228/1-G)
- Primed and painted exterior
- Removal of bulk liquid and contamination
- Oversized expansion chamber (3X port size) improves water removal efficiency
- Robust construction for automotive type applications
- CRN Registered (CRN# OH11715.5ADD1)



**Specifications**

Drip Leg Expansion Chamber	Port Sizes 1/4 to 1 1/2 - Schedule 40 Steel Pipe
	Port Size 2 - Schedule 80 Steel Pipe
Ball Valve Material	Bronze
Maximum Operating Pressure	150 PSI (125 PSI Maximum with Inlet Ball Valve)
Temperature Range	50°F to 200°F (-20°F to 200°F w/o Ball Valves)

**How to Order**

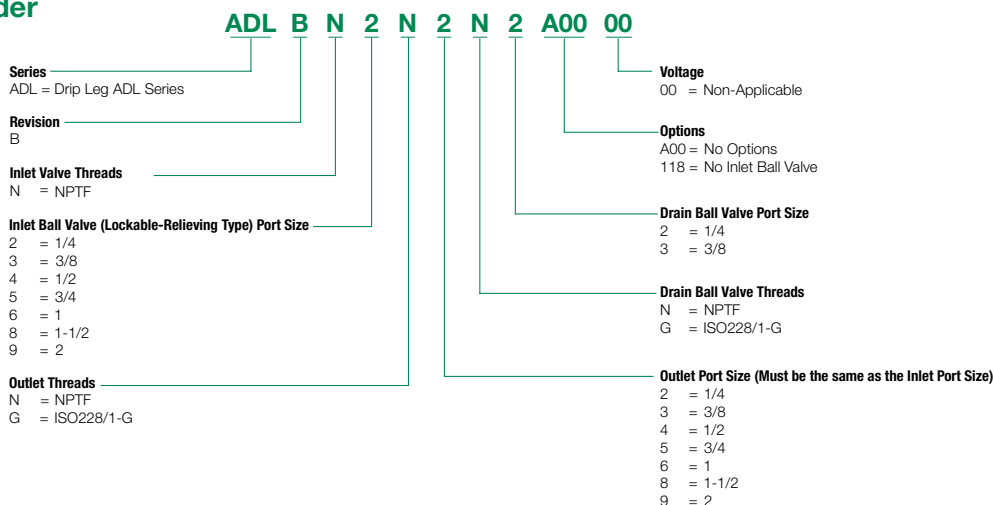

Dimensions: Inches

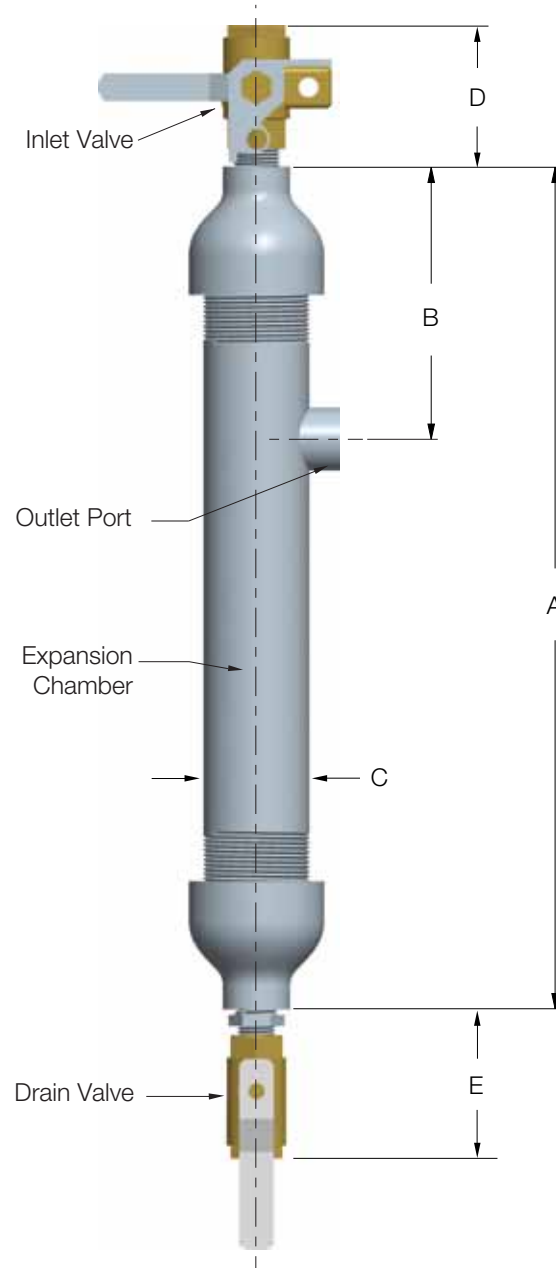

### Drip Leg Dimensions

Model	A	B	C	D	E*
1/4	15.2	4.9	1.9	2.7	2.7
3/8	15.2	4.9	1.9	2.7	2.7
1/2	15.2	4.9	1.9	2.4	2.7
3/4	18.0	6	3.5	4.2	2.8
1	18.0	6	3.5	4.3	2.8
1 1/2	19.5	7.1	5.6	5.5	2.4
2	20.4	7.5	6.6	5.7	2.4

\*Add 0.5" when using BSPP Port Threads (G ISO 228/1).



World Class Supplier of Pneumatic Components



## World Headquarters

### **USA Numatics, Incorporated**

46280 Dylan Drive  
Novi, Michigan 48377

P: 248-596-3200  
F: 248-596-3201

### **Canada Numatics, Ltd**

P: 519-758-2700  
F: 519-758-5540

### **México - Ascomatica SA de CV**

P: 52 55 58 09 56 40 (DF y Area metropolitana)  
P: 01 800 000 2726 (Interior de la República)  
F: 52 55 58 09 56 60

### **Brazil Ascoval Ind.e Comercio Ltda**

P: (55) 11-4208-1700  
F: (55) 11-4195-3970